



PROMOTING EXCELLENCE IN THE GLOBAL PRESSURE VESSEL AND PIPING INDUSTRY

**ASME 2018 PVP® CONFERENCE
JULY 15-19, 2018
PRAGUE HILTON
PRAGUE, CZECH REPUBLIC**



PARTICIPATE IN EXCELLENCE

PICK THE SPONSORSHIP* LEVEL THAT WORKS BEST FOR YOU

With four levels to choose from, you'll find a sponsorship package that connects your company to your customers with the participation level, brand presence and expertise visibility needed to get your unique message across.

** Each sponsor from 2017 has the first right of refusal for sponsorship renewal.*

PLATINUM

\$10,000/€8,479

Your company receives:

- ½ page ad in Mechanical Engineering, reaching more than 100,000 readers worldwide.
- ½ page ad in the conference program
- 10' X 8' exhibit booth
- 2 full conference registrations
- Promotional material distributed at registration
- Logo in conference program and on conference website
- Sponsor recognition at keynote address

Plus choose your level of participation and recognition:

Conference Opening Reception — Your company will be announced as a platinum sponsor at the reception and your logo will be displayed prominently inside and outside the reception hall. Your company will also have a reserved table at the reception.

OR

Student Paper Competition (2 available) — Your company name will be attached to one competition level of the two available (BSc/MSc or PhD), and your company logo will be included on all related event communication materials and signage. A representative from your company will be invited to present the sponsored award at the Honors Assembly.

OR

Wednesday Social Event Entertainment

(1 available) — Your company name and logo will be associated with the event entertainment for the Social Event on Wednesday night of the Conference. A representative from your company is invited to introduce the entertainment for this event. Your company logo will be on all related signage.



GOLD

\$5,000/€4,240

Your company receives:

- ¼ page ad in Mechanical Engineering, reaching more than 100,000 readers worldwide.
- ½ ad in the conference program
- 10' X 8' exhibit booth
- 1 full conference registrations
- Promotional material distributed at registration
- Logo in conference program and on conference website
- Sponsor recognition at keynote address

Plus choose your level of participation and recognition:

Special Welcome Gift — Your company's logo will be printed on conference gift given to all attendees.

OR

Lanyards — Your company's logo will be printed on the lanyards worn by conference delegates for the duration of the conference.

OR

Daily Author's Breakfast Program (4 available) — Your company's name and logo will be prominently displayed inside and outside the breakfast area.

OR

Student Paper Competition (2 available) — Your company name will be attached to one competition level of the two available (BSc/MSc or PhD), and your company logo will be included on all related event communication materials and signage.

OR

Conference Proceedings and Paper Access Site (1 available)

— Your company name and logo will be placed on the Conference Proceeding and Paper Access Site. Your Logo will also appear in the Sponsorship signage.



SILVER

\$3,500/€2,968

Your company receives:

- ¼ page ad in the conference program
- 10' X 8' exhibit booth
- 1 full conference registration
- Promotional material distributed at registration
- Logo in conference program and on conference website
- Sponsor recognition at keynote address

Plus choose your level of participation and recognition:

Daily Refreshment Break (4 available) — Your company's name and logo will be prominently displayed at the break areas on the day of your choice.

OR

Conference Portfolios (4 available) — Your company's logo will be printed on portfolios given to all attendees.

OR

Special Tutorials (Sunday pre-conference, 4 available) — Your company's name and logo will be prominently displayed during the Special Tutorials and on all related signage.

OR

Daily Guest Breakfast Program (4 available) — Your company's name and logo will be prominently displayed inside the breakfast area and on all related signage.

Sponsorship contracts and terms & conditions are available for download at on the ASME website.

Please visit www.asme.org/events/pvp



BRONZE

\$2,500/€2,120

Your company receives:

- Promotional material distributed at registration
- Logo in conference program and on conference website
- Sponsor recognition at keynote address

Plus choose your level of participation and recognition:

Pens — Your company's logo will be printed on pens given to all attendees at registration.

OR

Special Tutorials (Sunday, pre-conference, 2 available) — Your company's name and logo will be prominently displayed during the Special Tutorials and on all related signage.

OR

Technical Committee Lunch (2 available) — Your company's logo will be prominently displayed during the committee lunches on the day of your choice.

OR

Conference Social Event (2 available) — Your company's logo will be prominently displayed at the special event, loading area, transports and other event promotional items.

EXHIBITION PACKAGE**

Participate in the conference exhibition and Technology Demonstration Forum and you'll have the opportunity to network with delegates, present and demonstrate your products, generate sales leads and raise your profile within the Pressure Vessels & Piping industry.

Booth Options (includes one table and two chairs):

20' X 8' booth (6.1m X 2.4m)

10' X 8' booth (3m X 2.4m)

Each booth package includes:

Recognition — You'll be recognized as an exhibitor on event signage and on the conference website with link to your company's website.

Advertisement — Your company's participation and booth location will be acknowledged in the conference program.

*** Please contact ASME for booth pricing and preferred location.*

CONTRACT FOR SPONSORS & EXHIBITORS

1. Company Information

COMPANY NAME _____

CONTACT	TITLE	ADDRESS		
CITY	STATE	ZIP	COUNTRY	
PHONE	FAX	E-MAIL	WEBSITE	

SIGNATURE _____ DATE _____

2. Sponsorship (VAT not included in pricing)

PLATINUM (\$10,000/€8,479) GOLD (\$5,000/€4,240) SILVER (\$3,500/€2,968) BRONZE (\$2,500/€2,120)

PREFERRED SPONSORSHIP OPTION: _____

3. Exhibition – Technology Demonstration Forum (A two-day event occurring on Monday & Tuesday of the conference) (VAT not included in pricing)

10X8 BOOTH (\$1,500/€1247) 20X8 BOOTH (\$3,000/€2,493)

BOOTH NUMBER: FIRST PREFERENCE/SECOND PREFERENCE _____

4. Total Amount of this Order

AUTHORIZED SIGNATURE _____	DATE _____
NAME (PLEASE PRINT) _____	TITLE _____

5. Payment

INVOICE CREDIT CARD CHECK

Invoice – Upon receipt of this signed agreement you will be invoiced and payment is due 10 days from receipt of invoice.

Check: If paying by check, make check payable to ASME/PVP2018. Send check along with this form to:
ASME • Attn.: Jamie Hart • 11757 Katy Freeway • Suite 380 • Houston, Texas 77079

Please provide contact for Exhibit/Forum related correspondence:

NAME _____	E-MAIL _____	PHONE _____
------------	--------------	-------------

Please provide your company description and logo:

Enter your Company/Product/Service description (75 words or less): _____

Please e-mail a high-resolution company logo to Jamie Hart (hartje@asme.org) for publishing on the conference website and program.

Please visit www.asme.org/events/pvp to review Terms & Conditions of ASME event sponsorship and conference exhibition participation.

Join in helping us build excellence into the future of the PVP industry worldwide with an ASME PVP® 2018 Conference Sponsorship.

Set your sights on the 2018 Pressure Vessels & Piping® Conference where we will promote excellence in the global pressure vessel and piping industry. Rub shoulders with colleagues representing dozens of international industries. Imagine what you'll learn from the 180+ paper and panel sessions, tutorials, the Technology Demonstration Forum and the 26th Rudy Scavuzzo Student Paper Symposium and Competition.

You'll be presenting your ideas and networking with your colleagues in ASME's global community. What better event to develop opportunities than a conference that is renowned for fruitful exchanges of ideas and innovation with eager participants from 40+ countries around the world. And what more ideal place to celebrate and learn than in the historical and culturally rich, old world capital of Prague!

Technical areas will include developments in Codes & Standards; design methodologies including:

- Elastic-Plastic Analysis,
- Non-Destructive Evaluation, Diagnosis, and Prognosis,
- Fitness-for-Service,
- Operation & Maintenance,
- Fatigue (including environmental, stress corrosion, residual stresses, fracture toughness, elevated temperature components, dynamically loaded structures, flow-induced vibration)
- Risk-Based Assessment.

Conference features will include:

- 180+ Paper & Panel Sessions
- Technology Exhibition
- Tutorials
- 26th Rudy Scavuzzo Student Paper Symposium & Competition

General Topics will include:

- Codes & Standards
- Design Analysis
- High Pressure Technology
- Operations, Applications & Components
- Non-Destructive Examination
- Computer Technology & Bolted Joints
- Fluid Structure Analysis
- Materials & Fabrication
- Seismic Engineering

* based on 2017 data.

Organizations Represented*

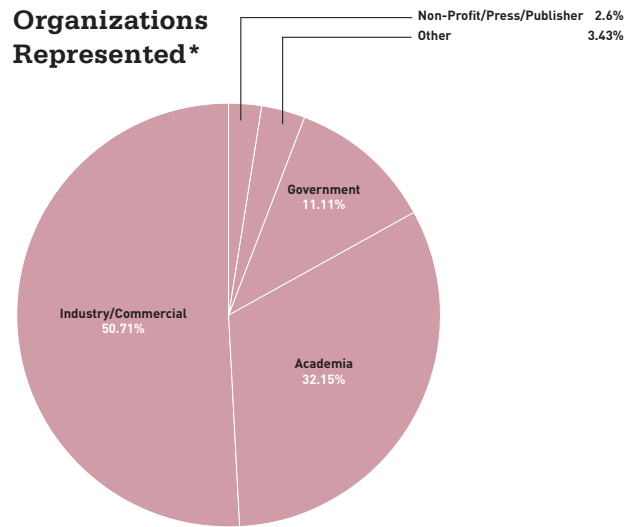

Typical Participant Roles*

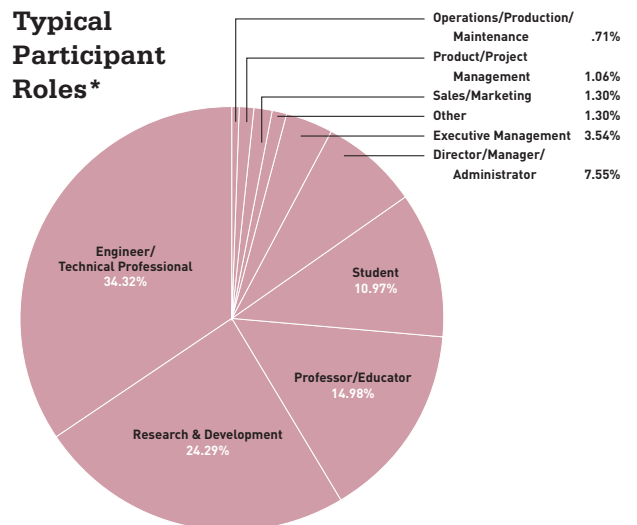

Level of Purchasing Authority*

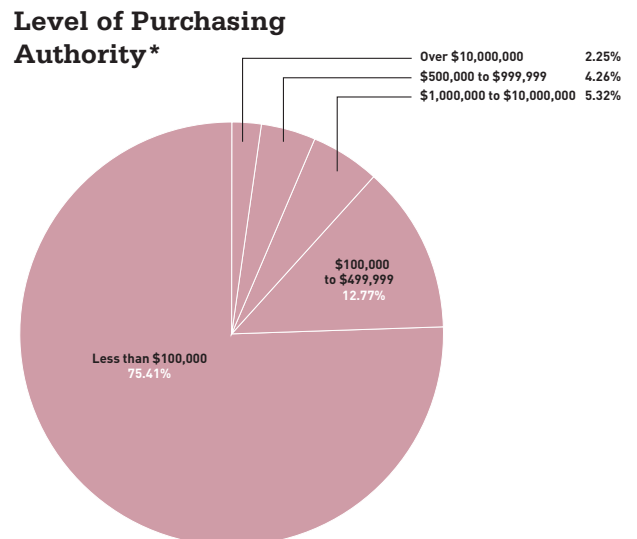

Hilton Prague Congress Hall Foyer I-III

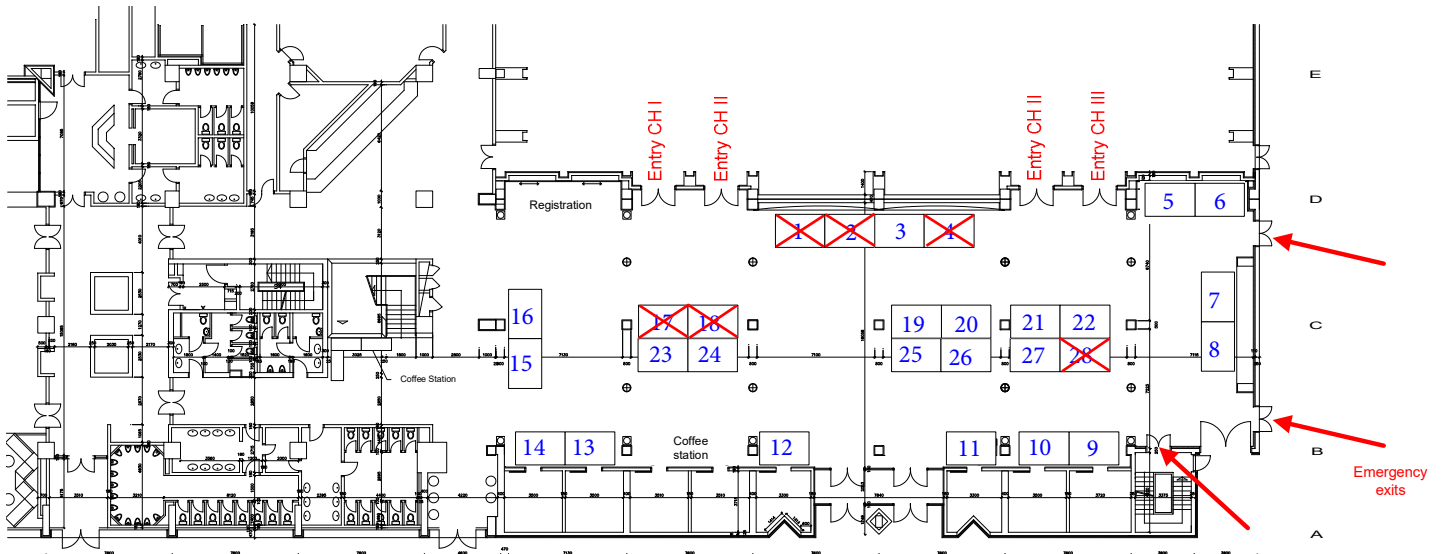

The PVP® Conference is a recognized forum for the fruitful exchange of ideas and innovation with participants from more than 40 countries worldwide. This year, the 2018 ASME PVP Conference is being co-sponsored by the ASME NDPD Division. So come to Prague, meet your colleagues, and help us create and advance our technologies for our global community. For more information please visit www.asmeconferences.org/PVP2018/.

PVP Conference Chair:

Pierre Mertiny
University of Alberta, Mechanical
Engineering Department
Phone: 780.492.6982
Fax: 780.492.2200
Email: pmertiny@ualberta.ca

PVP Technical Program Chair:

Hakim Bouzid
École de Technologie Supérieure
(Montreal)
Mechanical Engineering Department
Phone: 514.396.8563
Fax: 514.396.8530
Email: hakim.bouzid@detsmtl.ca

Sponsorship Chair:

Carl E. Jaske
HSI Group, Inc.
Phone: 310.517.8700
Fax: 310.517.8701
Email: cjaske@hsigroup.com



For more information about the PVP Conference, sponsorship levels and exhibit opportunities, please visit our website: www.asme.org/events/pvp or contact:

ASME Sales

Greg Valero
1.212.591.8356
valerog@asme.org

ASME Sponsor & Exhibitor Service

Jamie Hart
Manager, Conferences & Events
1.281.810.5453
hartje@asme.org